

# Medium and high level order picking



worldwide network

2

models

24/7  
support



order pickers

EPM • EPH



**IFOY AWARD**  
international forklift truck  
of the year 2017





UniCarriers designs, manufactures and supports the most advanced material handling equipment. By integrating the three distinctive brands of Atlet, Nissan Forklift and TCM, UniCarriers is the perfect mixture of Japanese quality and technology as well as Swedish design and ergonomics. UniCarriers represents more than 65 years of industry experience, an unparalleled global reach and deep understanding of local markets.

# The correct decision

In every materials handling operation, each handling method is a necessary function without which the whole process would collapse into a lost mountain of time, people and thereby money. Each handling method is a part of your Materials Handling costs and order picking is by far the most important. Any order picking function that cannot be automated requires people.



The number of working hours required to perform an order picking operation is far in excess of the working hours for all remaining functions added together.

This labour-intensive operation becomes the most expensive of all your materials handling costs and this makes the selection of your order picking equipment a decision that will determine how well you keep these costs under control and allow your profitability to increase.

**There are 7 important closely linked areas that will need serious consideration:**

1. The total **Materials Handling** system and the order picking methods employed within
2. **Ergonomics** and how this affects the operators comfort and productivity
3. **Productivity** of the order picking system and equipment
4. **Customised** equipment designed to fulfil your order picking needs
5. **Safety** in terms of equipment design and how this is influenced by the order picking system
6. **Reliability and Uptime** of the equipment will have a major influence on the running costs of your order picking system
7. **Manoeuvrability** resulting from clever design, using space to a premium and thereby keeping costs to a minimum





5

1

2

4

3

6

7



**UNICARRIERS**



# The right way

## to carry out an order picking function

Many suppliers will aim for flexibility of equipment and many more will pursue the lowest possible price as their primary goal. However, both of these strategies ignore the crucial Total Materials Handling Cost.

UniCarriers will identify the most time-efficient order picking system and equipment for your individual needs, thereby reducing your total cost of operation:

- High performance order picking
- Highest safety levels
- Lowest total cost of operation
- Most time-efficient picking strategy



**UNICARRIERS 360°**

Within the UniCarriers sales organisation we employ Cost Reduction Specialists. Their aim is to help you build a handling system that provides and sustains all four of these areas and takes into consideration all other important functions within your overall operation. A 360 degree study.



**LOGISTICS  
ANALYSER**

To assist these specialists we provide them with our highly acclaimed simulation software "Logistics Analyser". With this program we can design your materials handling system and simulate all the alternative order picking methods available, to establish the most suitable for you. Suitable in terms of high performance, most efficient utilisation of time, high levels of safety and the lowest total cost of operation.

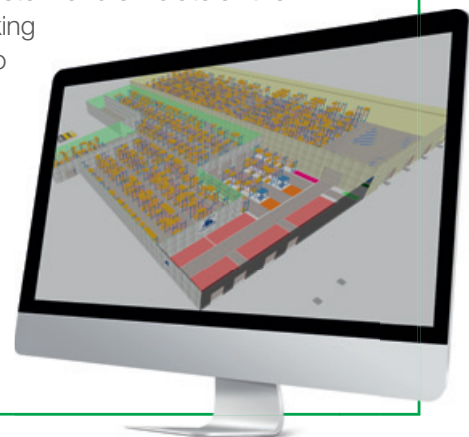



**UNICARRIERS**







23 %

increase in the  
maximum picking  
height

11 %

higher order picking  
productivity



# Ergonomics...

The applied science of equipment design, which in the workplace maximises productivity, prevents injury and minimises operator fatigue. UniCarriers take a 360 degree view of ergonomics.



1

## 1. Driver-friendly cabin

- **Visibility** through the main ProVision mast
- **Visibility** through the front of the picking cabin
- This provides safety, performance and cost effectiveness

## 2. and 3. Adaptable controls

- **Designed** to fit neatly in both hands
- **Adjustable** up & down with forward and backward rotation to suit all operators
- **Controls** front or back of cabin

## 4. Designed for Order Picking

- **Multiple storage compartments** for everything the operator needs while order picking

## 5. and 6. Looking out for the operator

- Low step-in height
- Pro Access gates
- Wide platform entry/exit

## 7. Battery access

- Easy access to the battery from above for checking the electrolyte status
- Easy pull-out access on steel rollers providing battery change-over for extended use

## 8. Multi positional Ergo Seat

- Fully adjustable to any position so it can be used as a comfort seat for longer travel distances, or as a comfortable lean-on cushion between picking locations



2



3



4





## 9. Intelligent use of vertical space

- Overhead guard for safety can also be used to attach other optional equipment like LED lights, mirror, cooling fan, radio, etc.

## 10. DPS – driver presence sensor

- The innovative DPS greatly improves ergonomics by replacing the old small dead man's switch. The floor panel is equipped with sensors to detect the driver in the cabin. This means that the operator does not push down on a pedal with one foot. The build-up of strain and pressure down one side of the body is avoided.

**dps**  
driver presence sensor

## Further benefits

- Designed to allow custom fitting of items such as barcode scanners, writing desk, document holders, cooling fan, computer terminal and picking labels
- Everything your operator needs to efficiently complete the order picking function
- Low noise for greater comfort (66db)





# Ergonomics + Safety

Safety is a UniCarriers priority and when it comes to order picking equipment, safety is paramount:

- For the operator
- For other people in and around the working area
- For products and manufacturing equipment in the area



# = Productivity

Productivity has close links to ergonomics and safety.

A comfortable order picking truck allows the operator to be productive. A safe machine allows the operator to utilise all of the truck performance benefits.



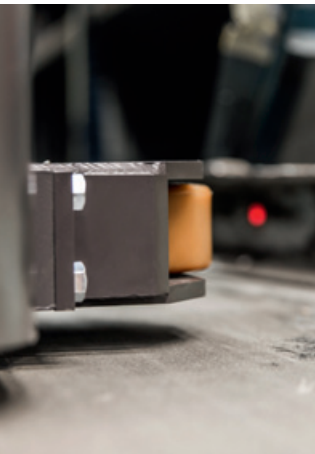



## Manoeuvrability

The ability to manoeuvre in confined areas allows full use of the available space. This ensures maximum storage capacity is realised. The ability to work in confined spaces with ease also means that skilled operators are able to avoid collisions and the associated costs.

Great visibility is fundamental to manoeuvrability. The great ergonomic design of cabin and chassis create circumstances that increase operator alertness and the ability to work in restricted areas in a safe manner.

Great design includes controls that can be adjusted to fit each and every operator. Custom fitting, great ergonomics and 360° visibility equal high productivity and maximum safety.

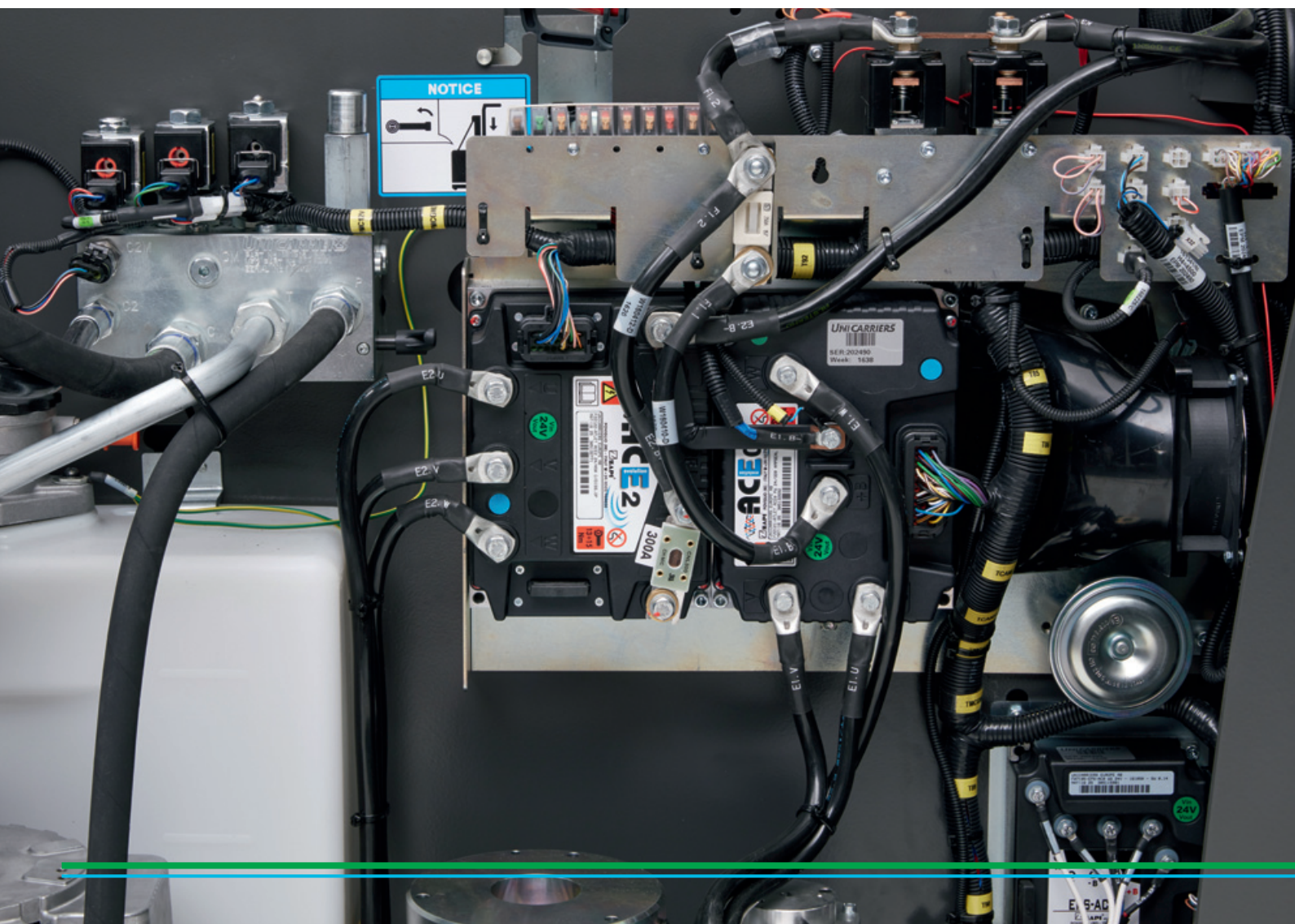



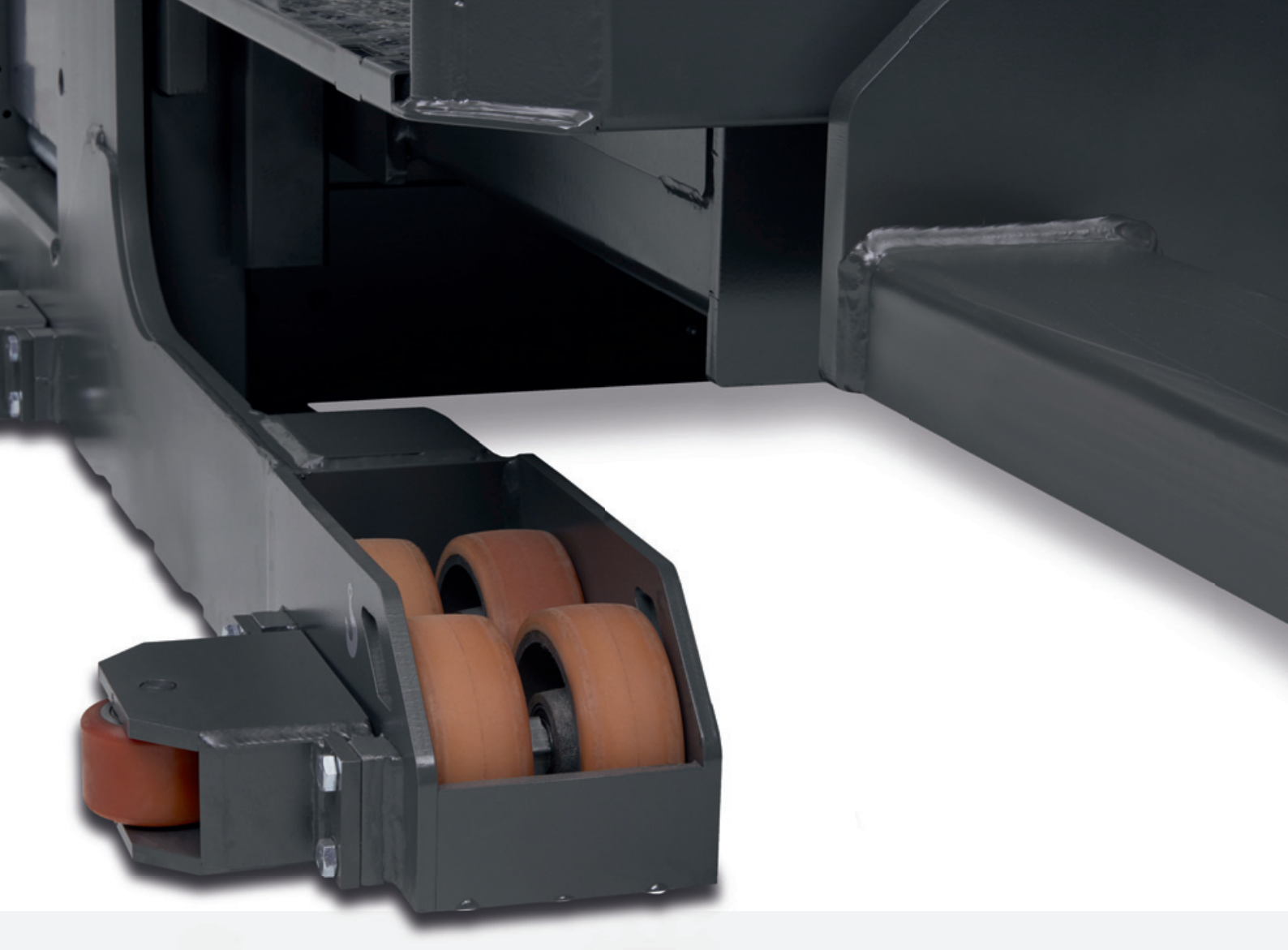

# Reliability & uptime

Design and build quality together provide equipment with excellent reliability and therefore high levels of uptime.

Great design provides excellent visibility, which prevents accident and damage, again increasing uptime.

- Rugged mast
- Solid front bumper
- Strong cabin rails
- Strong gates
- PIN code access avoids damage from unauthorised users
- PIN code allows driver settings to be optimised to each driver's skill level
- Truck computer provides engineers with diagnostic feedback information.
- Quick and easy battery access ensures maintenance of battery life

## Modular design gives ...

- High commonality of parts
- High parts availability
- High engineer familiarity
- High levels of uptime



# High level order picking

Order picking is the most time consuming and labour-intensive handling activity. This remains true regardless of the storage height of the pick location.

There should be no compromise in performance and no risks taken with safety. Order picking equipment should be designed to get the operator:

- As close to the pick location as possible
- As quickly as possible
- In the safest way possible

UniCarriers order picking range is complete with equipment designed to allow comfortable and time-efficient order picking with maximum levels of safety, and allows picking from floor level up to an unbeatable 12.1 meters. UniCarriers now offer two models with many different (modular designed) specifications. The **EPH** and the **EPM**. Both offer easy access for service engineers with high levels of uptime and extended time intervals between services.

## EPH

A 48 volt heavy duty high lift order picker with unmatched capacity of 1250 kg. Designed to reach picking heights previously unattainable with standard picking equipment. Picking safely from 12.1 meters, in a truly ergonomic environment. A fully equipped and uncluttered operator's cabin to provide the perfect work place for greatest productivity.





# at its best

## EPM

A 24 volt 1000 kg high lift order picker. Designed to reach picking heights of 9.85 meters This truck has many parts and features in common with its big brother, the EPH. The same rugged design with identical operator cabins for optimised comfort, safety and productivity.



## Customisation/ Adaptability

Each order picking operation has its own unique demands and often this means a custom-built, tailor-made solution in terms of the design of the picking equipment.

UniCarriers have historically designed special order picking trucks to fulfil the demands of special and unusual picking operations.

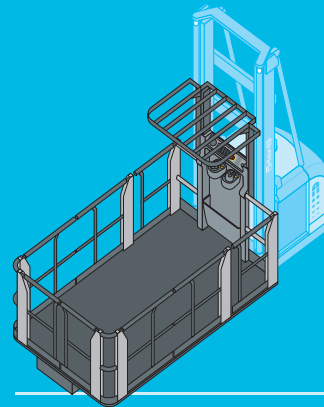

Long and wide platforms for picking and storing furniture of all sizes and suites. Ideal for the storage of complete suites together in one location.

Long platforms for picking long cumbersome loads, such as vehicle exhausts, plastic pipes and plastic extrusions. Simply, safely, accurately and quickly.

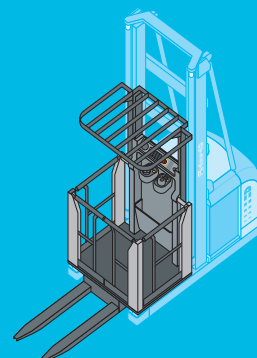
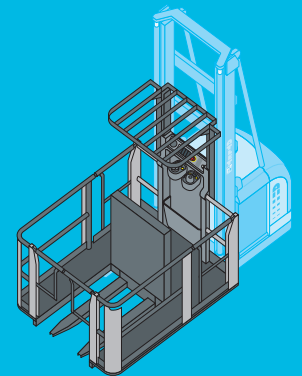

Ergo Picking trucks with front safety gates allow access to custom-designed load carriers.



It's all about  
the price.  
**But what  
price?**

## **Reduce your Total Cost of Operation with UniCarriers**

We agree. Price is everything. Or to be more specific: your Total Cost of Operation (TCO). That's why we're so focused on cutting costs and improving your material handling. The truck and its performance play an important role, but this is even more about how we can support you in optimising your warehouse operations to give you the best value for your money. Which – in the long run – is what creates a winner.