

PANORAMIC P 75.9CS

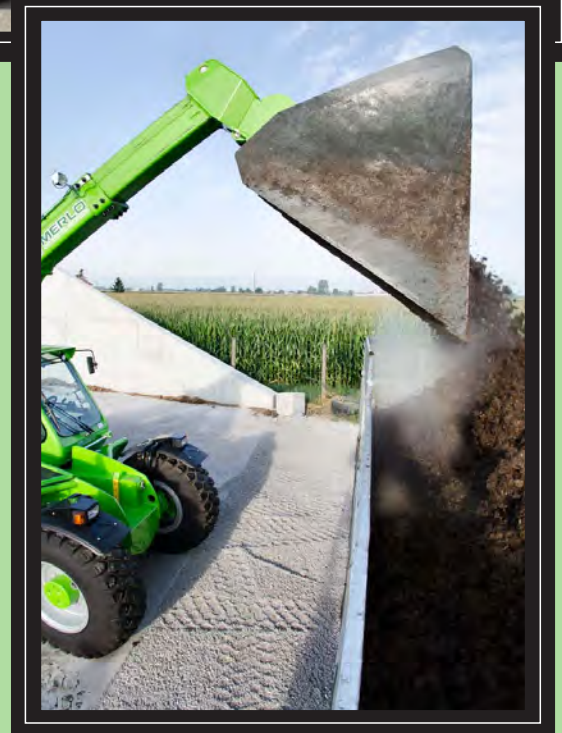
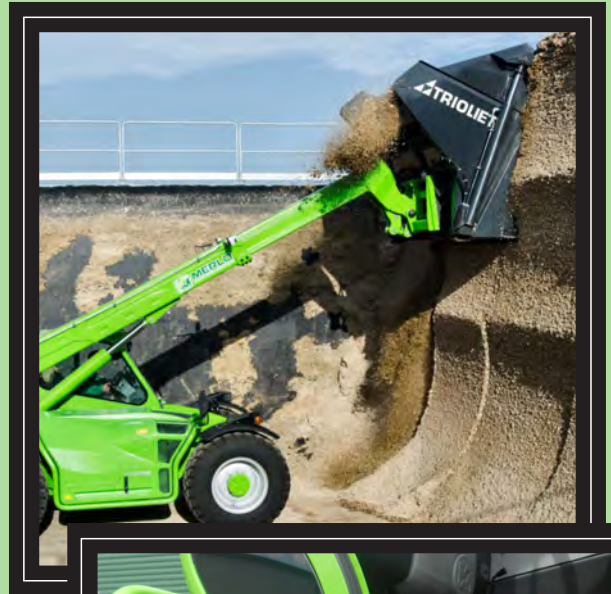

MERLO
AUSTRALIA

KEY SPECIFICATIONS

Total weight unladen with forks (kg)	11400
Maximum load capacity (kg)	7200
Maximum lift height (m)	8.8
Maximum forward reach (m)	4.6
Lift height at maximum capacity (m)	7.5
Forward reach at maximum load capacity (m)	1.3
Load capacity at maximum height (kg)	6500
Load capacity at maximum forward reach (kg)	2100
Engine (type/number of cylinders)	Turbo Diesel/4
Tier 3 engine power (kW/hp)	103/140
Fuel capacity (l)	150
Maximum speed (kph)	40
Load -sensing hydraulic pump (bar-l/min)	225-150
Hydraulic oil capacity (l)	110
Electrical circuit (V)	12
Battery (Ah)	100
Cab compliant with ROPS/FOPS standards	✓
4x1 Electro Proportional joystick controls	✓
Tac-Lock hydraulic attachment coupling	✓
Auxiliary boom hydraulics	✓
Two standard forks (1200mm)	✓
Hydrostatic transmission	✓
Finger touch direction control	✓
Inching pedal for precise control	✓
Permanent 4 wheel drive	✓
Four wheel steering	✓
Dry type disc brakes on all wheels	✓
Automatically locking parking brake	✓
17.5-25 22PR EM 20-60 tyres	✓
Rear differential lock	✓
Four cab working lights (2f & 2r)	✓
12V electrical on boom head	✓
Air suspension seat	✓
Front window protection	✓
Full size cab with air conditioning	✓
Stability control system	✓

Merlo engineers had a clear objective: designing safe and comfortable machines, features that both aim at improving working conditions. The Panoramic P75.9CS is equipped with active cab suspension, which ensures effective damping under all load, driving and speed conditions. Many innovative solutions have been introduced, adding to the leading visibility of Panoramic models, and ensure high performance typical of larger class machines, while maintaining the compact size and the manoeuvrability of small machines. Merlo design gives the model versatility in agricultural, construction, waste management and production applications. In all Merlo telescopic handlers the engine is mounted to the right side of the chassis, ensuring safe, easy access and maintenance from ground level.

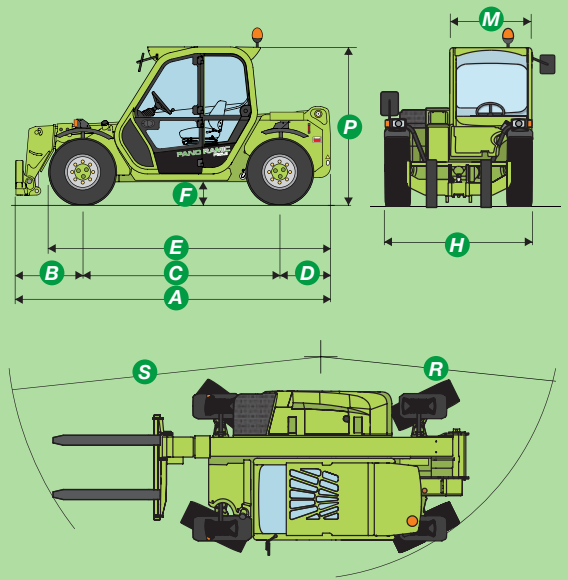

DIMENSIONS

A (mm)	5100
B (mm)	1190
C (mm)	3000
D (mm)	910
E (mm)	4610
F (mm)	450
H (mm)	2400
M (mm)	995
P (mm)	2540
R (mm)	3820
S (mm)	4850

P75.9CS Load Chart - Standard forks

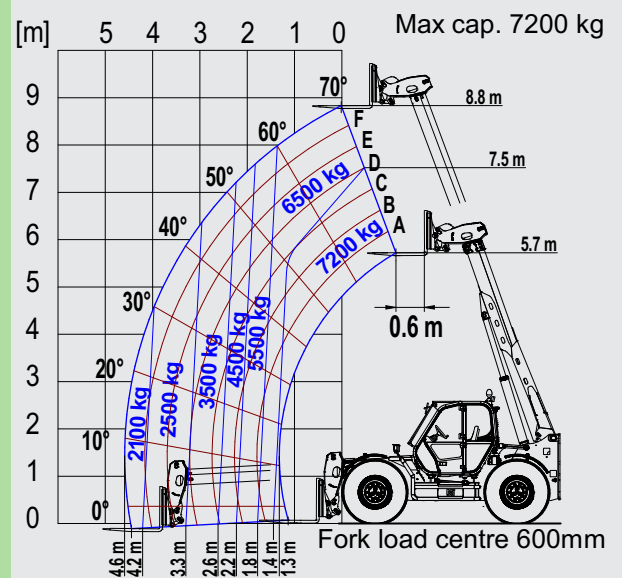

1300 657325
www.merlo.com